

Steel ball valves, reduced bore

female threads/welding, EN (DIN), DN 10-50

Properties

Body:	Steel, EN 10217-2 P235GH (1.0345)
Ball:	Stainless steel, EN X5CrNi18-10 (1.4301)
Stem:	Stainless steel, EN X8CrNiS18-9 (1.4305)
Stem seals:	FPM
Ball seals:	Carbonized PTFE
Thread	ISO 7/1 Rp
Operation:	With galvanized steel handle



Operating conditions

-30°C - +200°C

Below 0 °C contact manufacturer

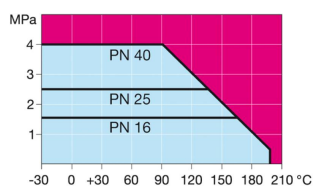

Not for steam

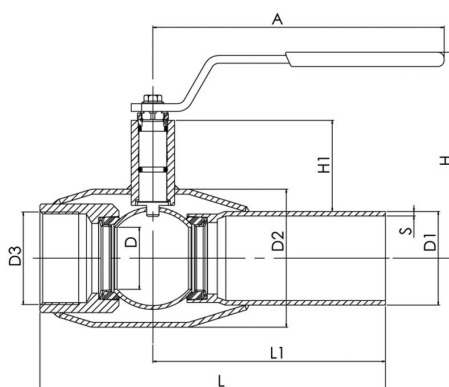

DN	PN	Product no.	D	D1	D2	D3	S	H	H1	A	L	L1	Kv	Kg
10	40	101 010	10	17,2	33,7	R 3/8	2	100	23	140	153	115	8	0,5
10	40	101 010/H	10	17,2	33,7	R 3/8	2	125	50	140	153	115	8	0,5
15	40	101 015	10	21,3	33,7	R 1/2	2	100	23	140	153	115	8	0,5
15	40	101 015/H	10	21,3	33,7	R 1/2	2	125	50	140	153	115	8	0,5
20	40	101 020	15	26,9	42,4	R 3/4	2,3	105	24	140	153	115	14	0,6
20	40	101 020/H	15	26,9	42,4	R 3/4	2,3	129	50	140	153	115	14	0,6
25	40	101 025	20	33,7	48,3	R 1	2,6	105	40	150	160	115	25	0,9
25	40	101 025/H	20	33,7	48,3	R 1	2,6	112	49	150	160	115	25	0,9
32	40	101 032	25	42,4	60,3	R 1 1/4	2,6	105	39	150	183	130	41	1,3
32	40	101 032/H	25	42,4	60,3	R 1 1/4	2,6	115	48	150	183	130	41	1,3
40	40	101 040	32	48,3	76,1	R 1 1/2	2,6	125	59	190	190	130	65	1,8
50	40	101 050	40	60,3	88,9	R 2	2,9	135	59	190	223	150	103	2,5

H=Higher stem